

1 [FGPJE] FLUXO GERAL PRINCIPAL

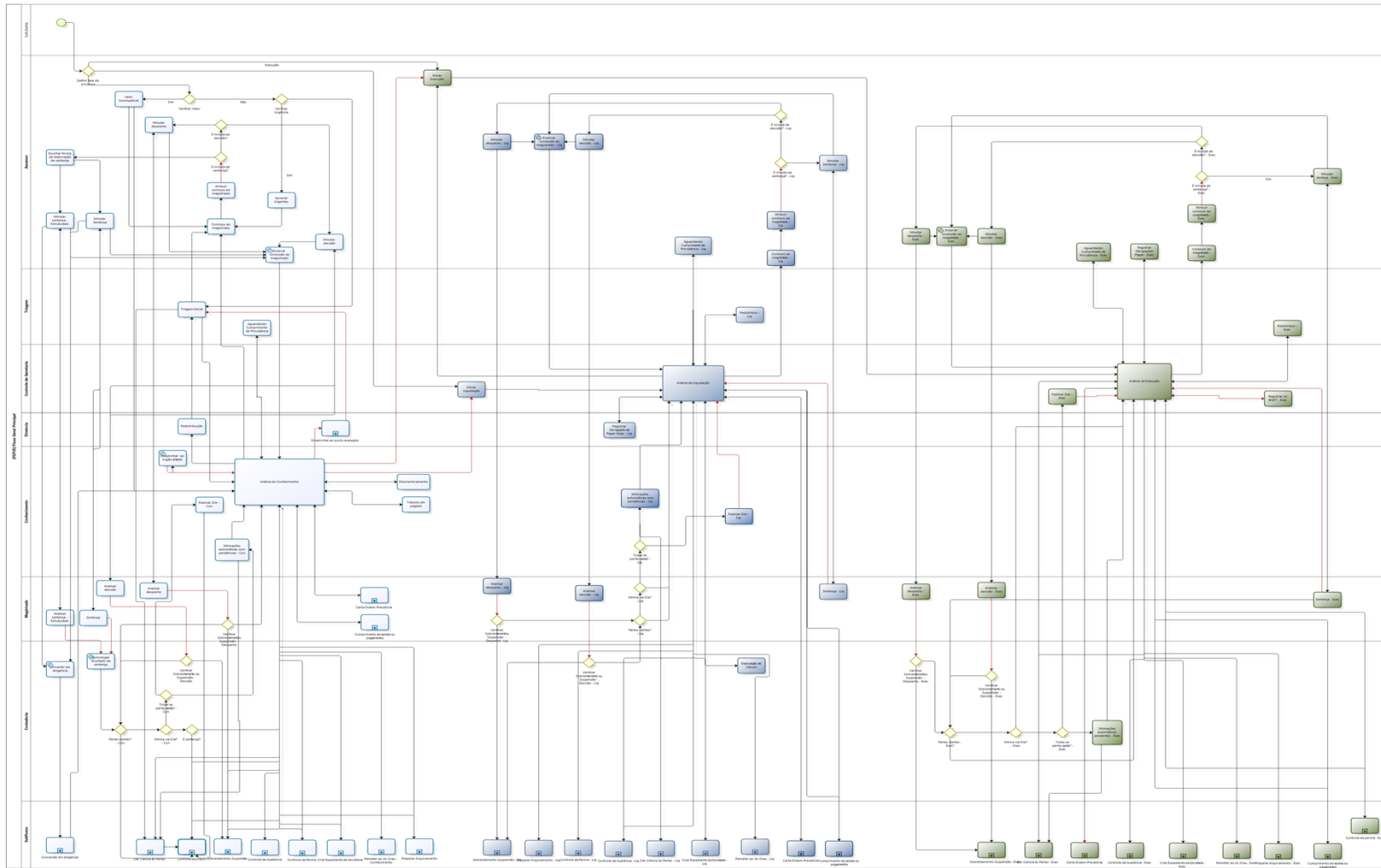

2 [CA] CONTROLE DE AUDIENCIA

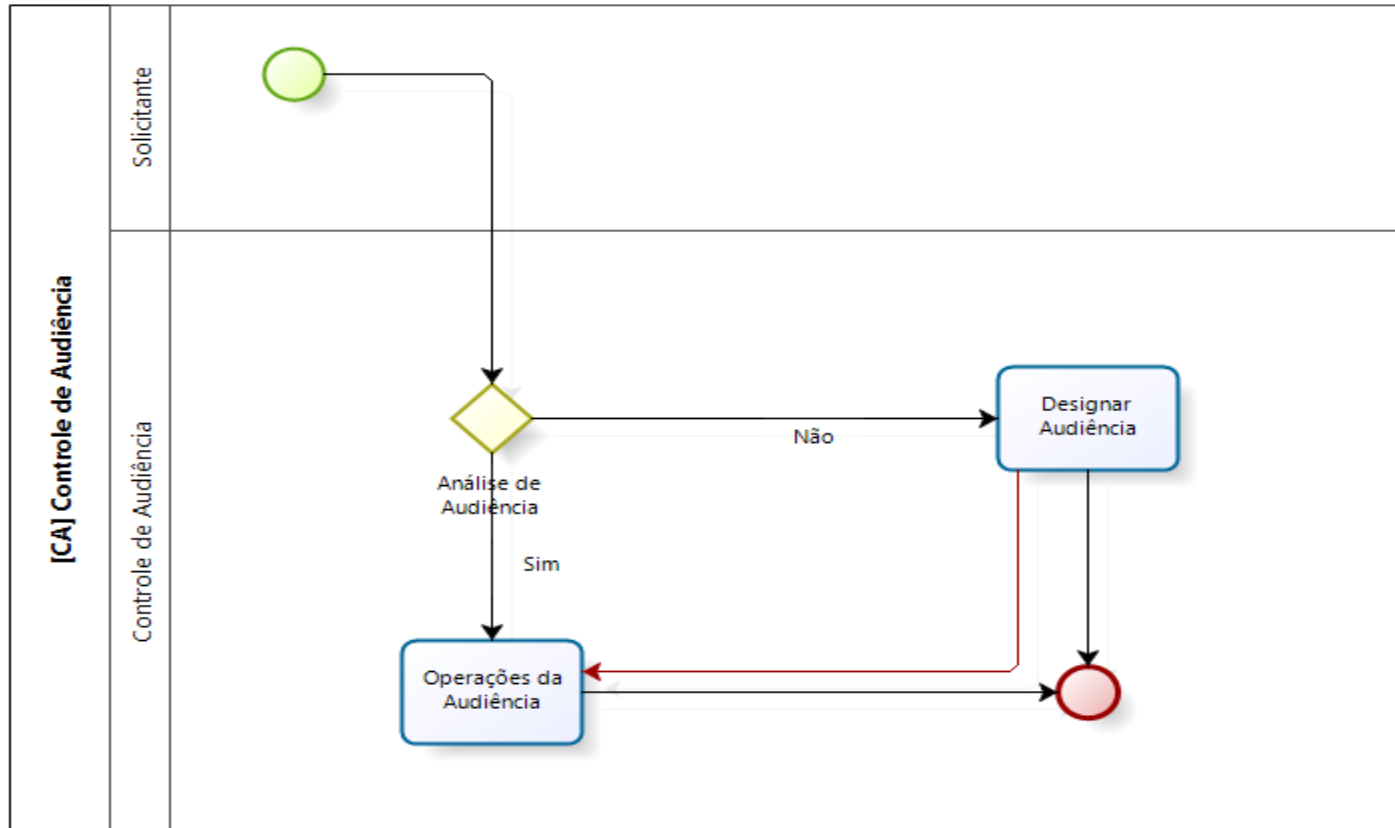

3 [PAC] PREPARAR ATO DE COMUNICACAO

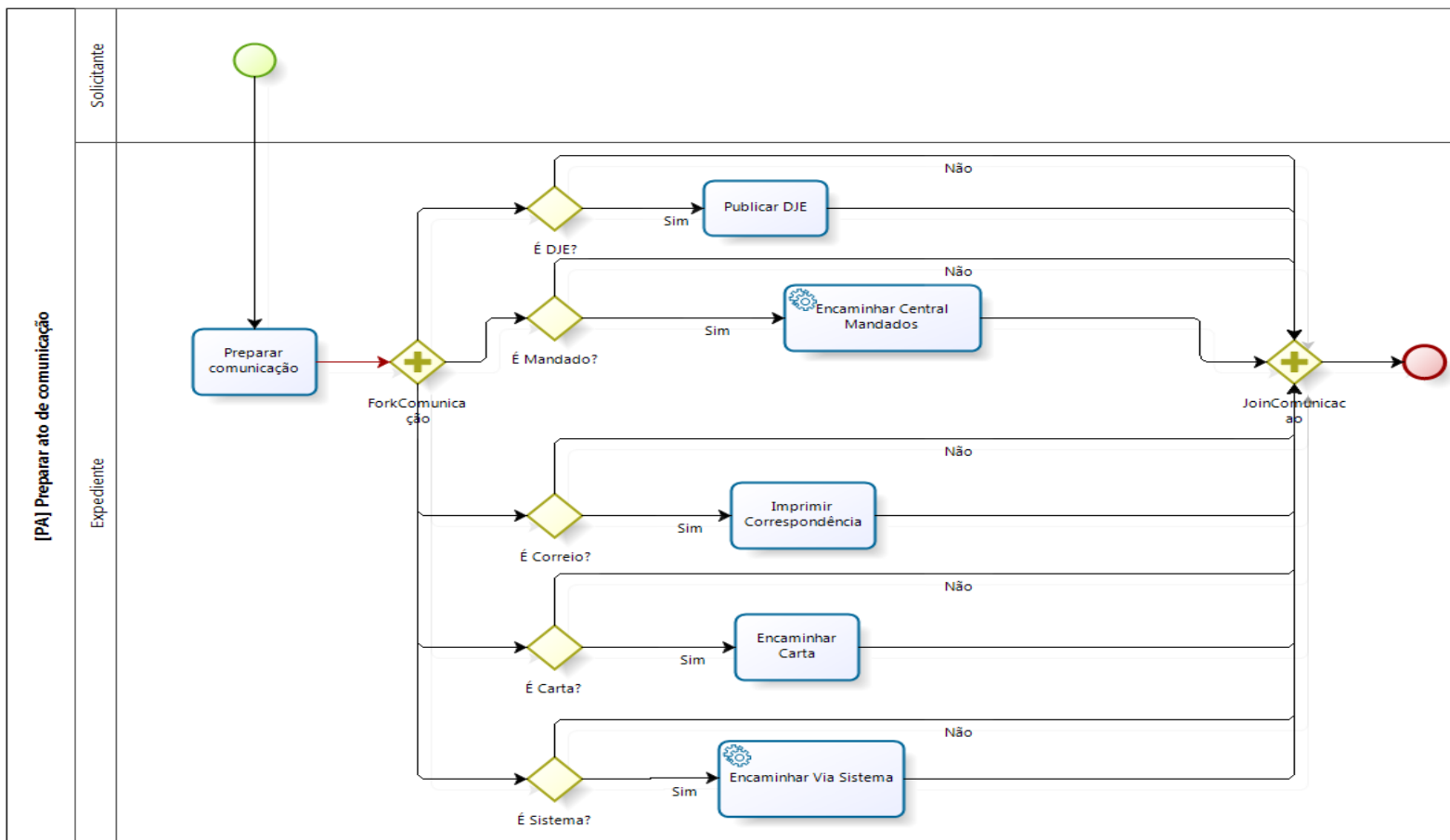

4 [PA] PREPARAR ARQUIVAMENTO

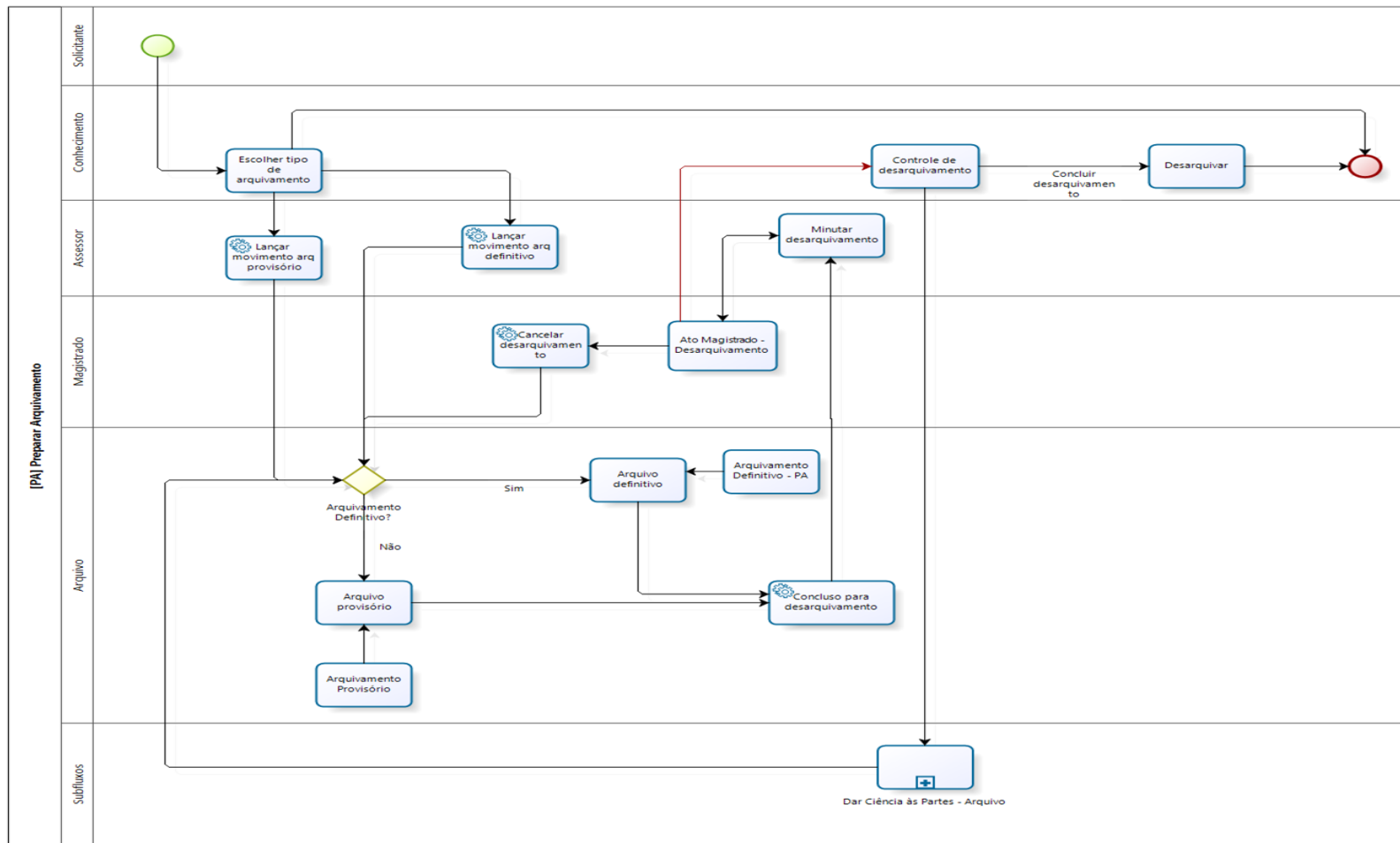

5 [CONPRA] CONTROLE DE PRAZOS

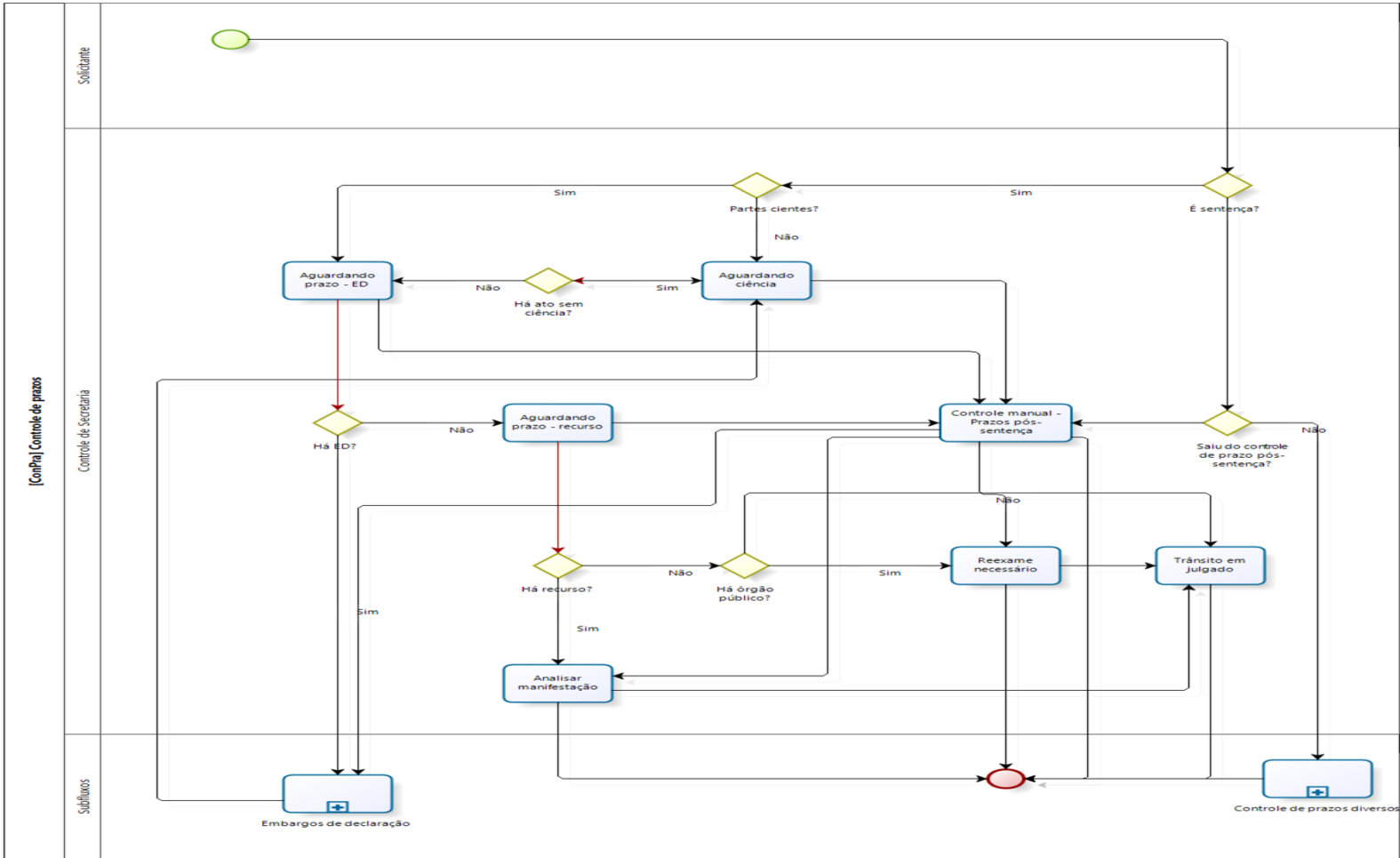

6 [CUMACORPAG] CUMPRIMENTO DE ACORDO OU PAGAMENTOS

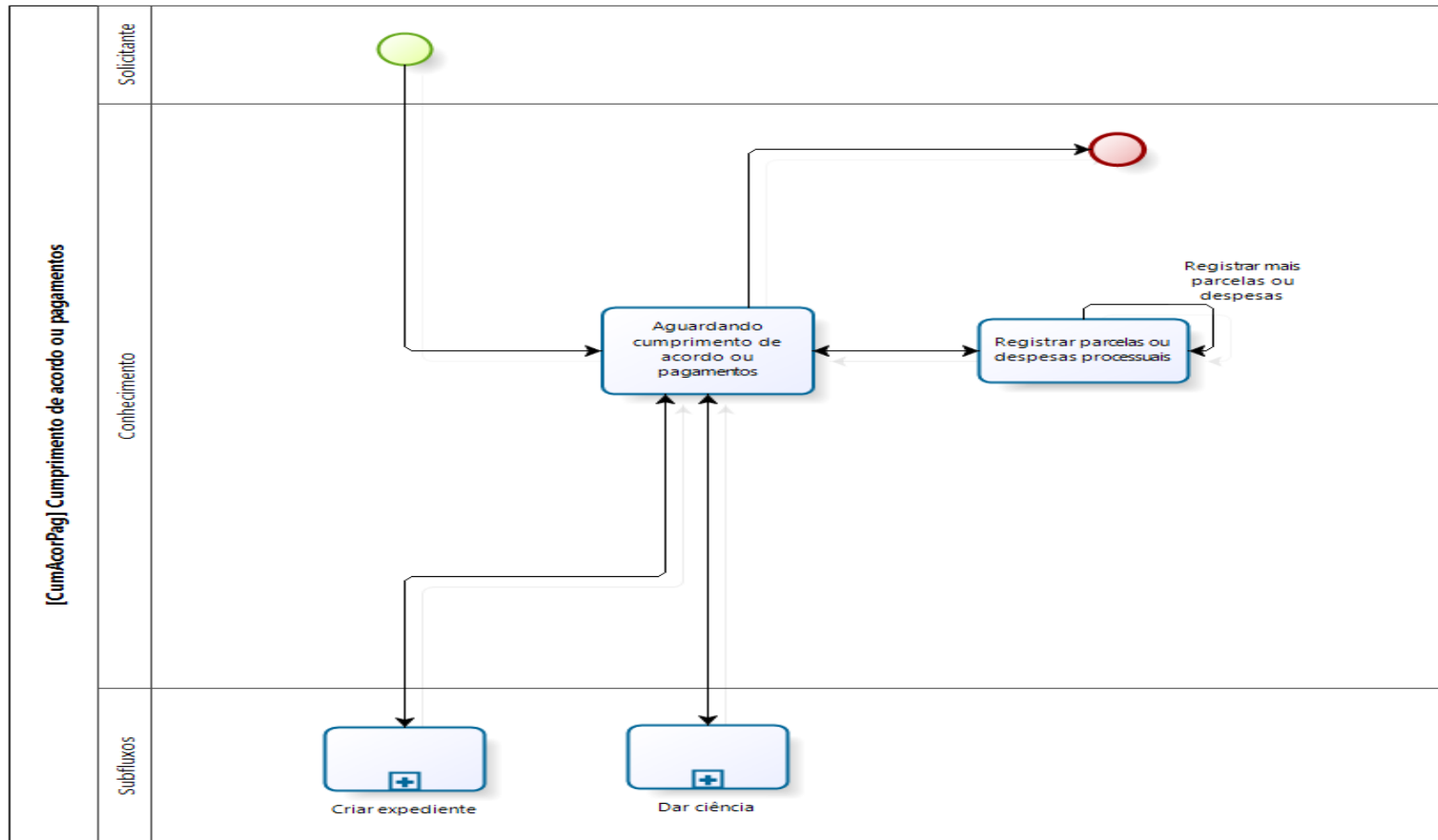

7 [CONVDILIG] CONVERSAO EM DILIGENCIA

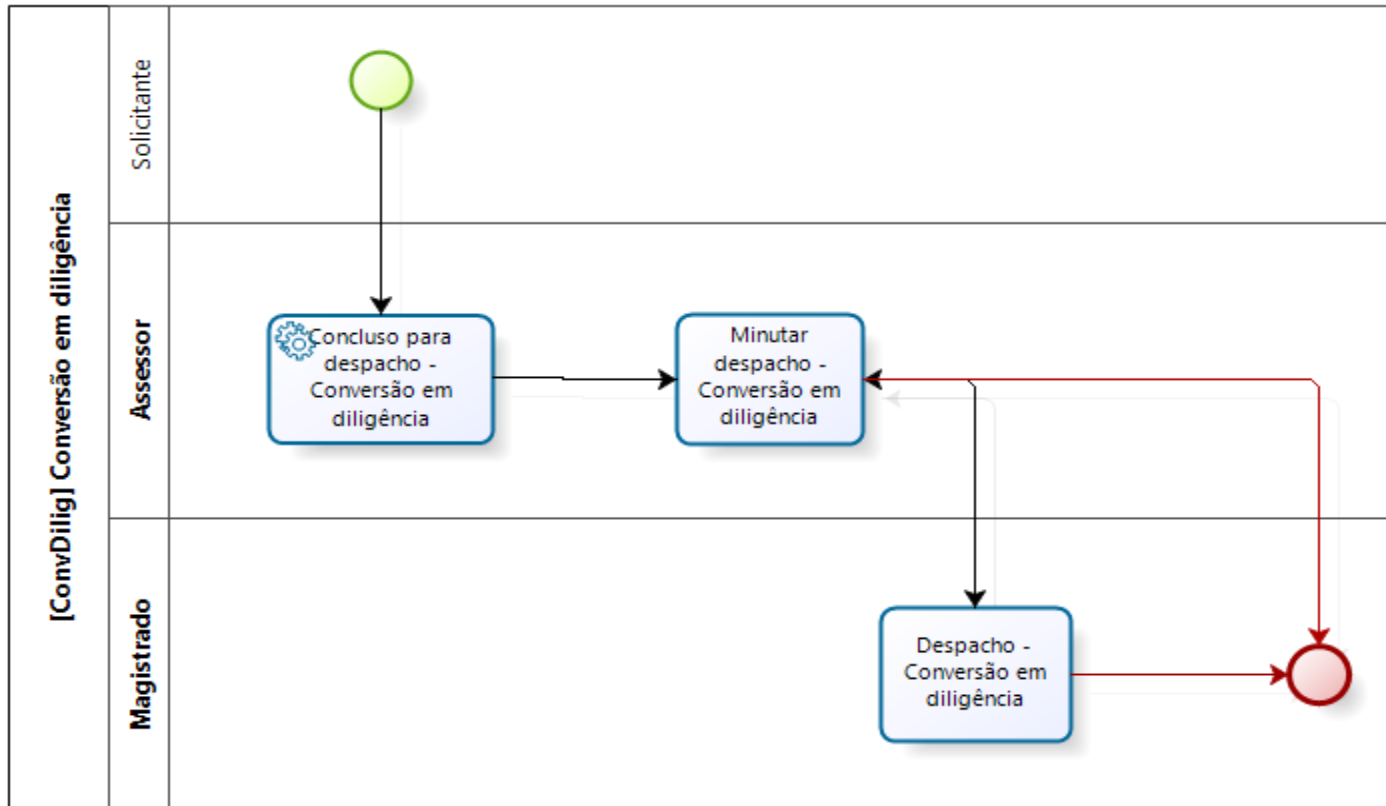

8 [CP] CONTROLE DE PERICIA

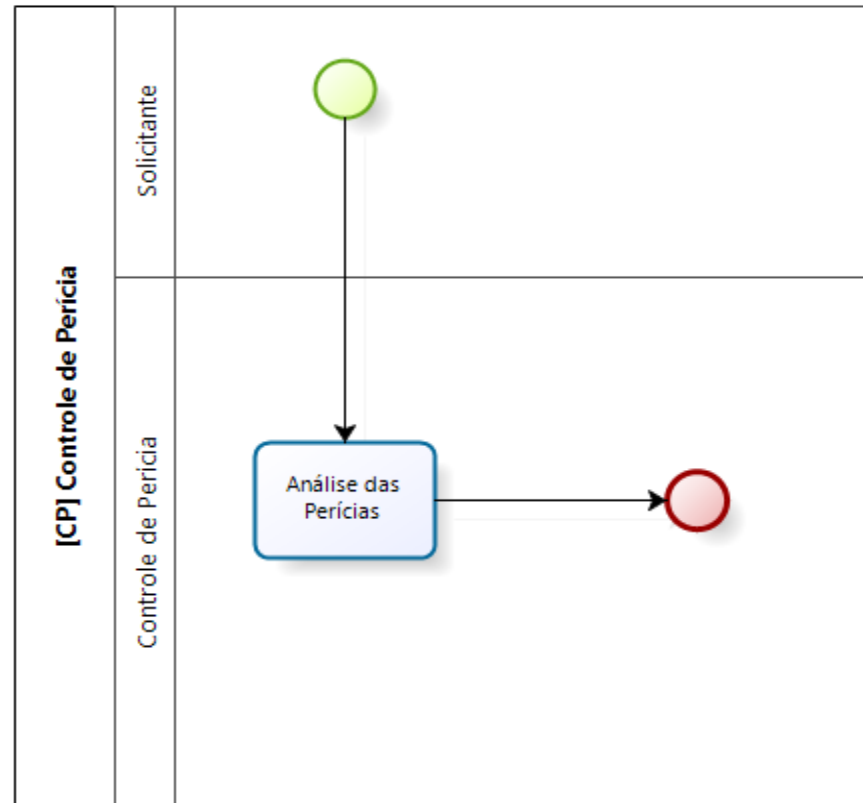

9 [CPDIV] CONTROLE DE PRAZOS DIVERSOS

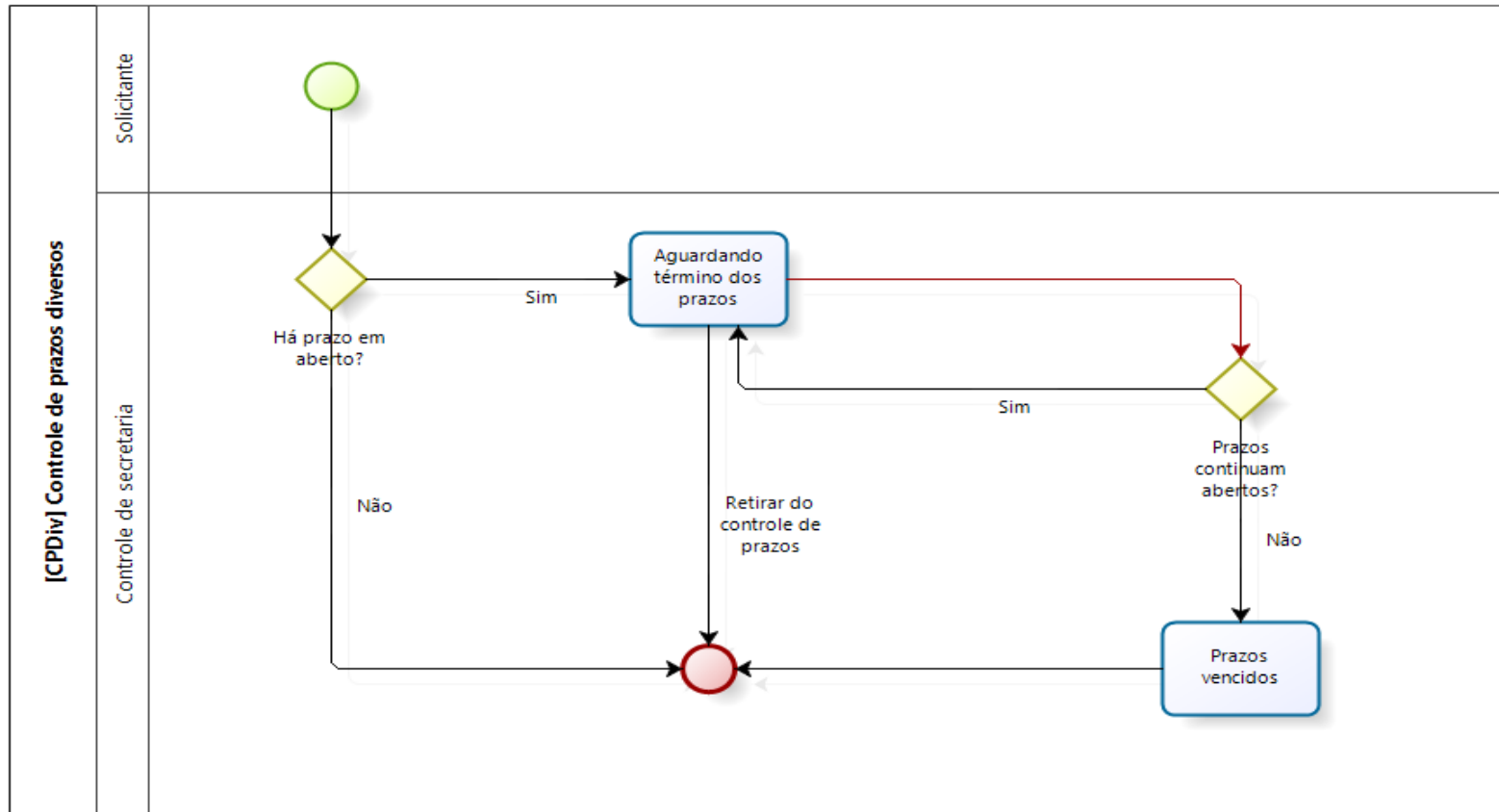

10 [CES] CRIAR EXPEDIENTE SECRETARIA

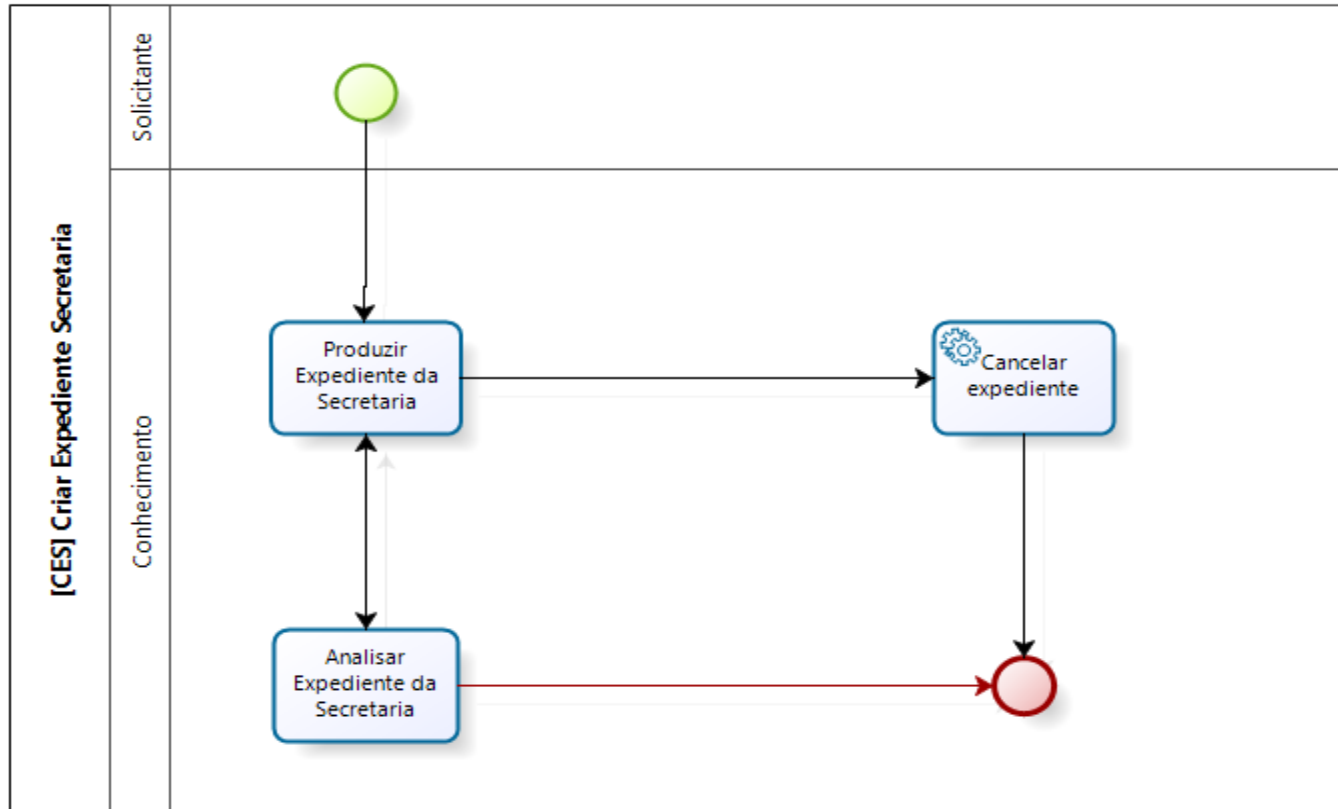

11 [ENCPA] ENCAMINHAR AO POSTO AVANÇADO

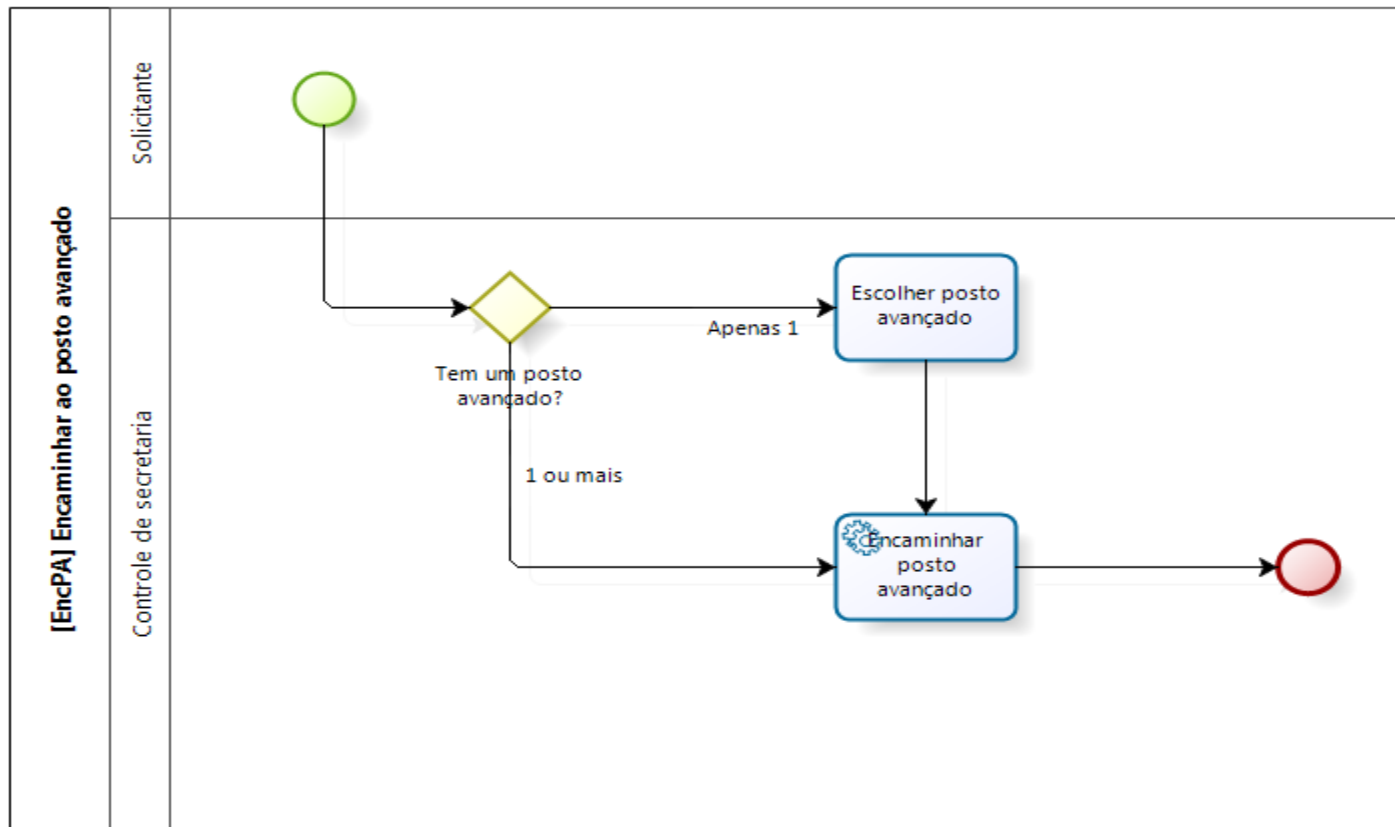

12 [S] SOBRESTAMENTO

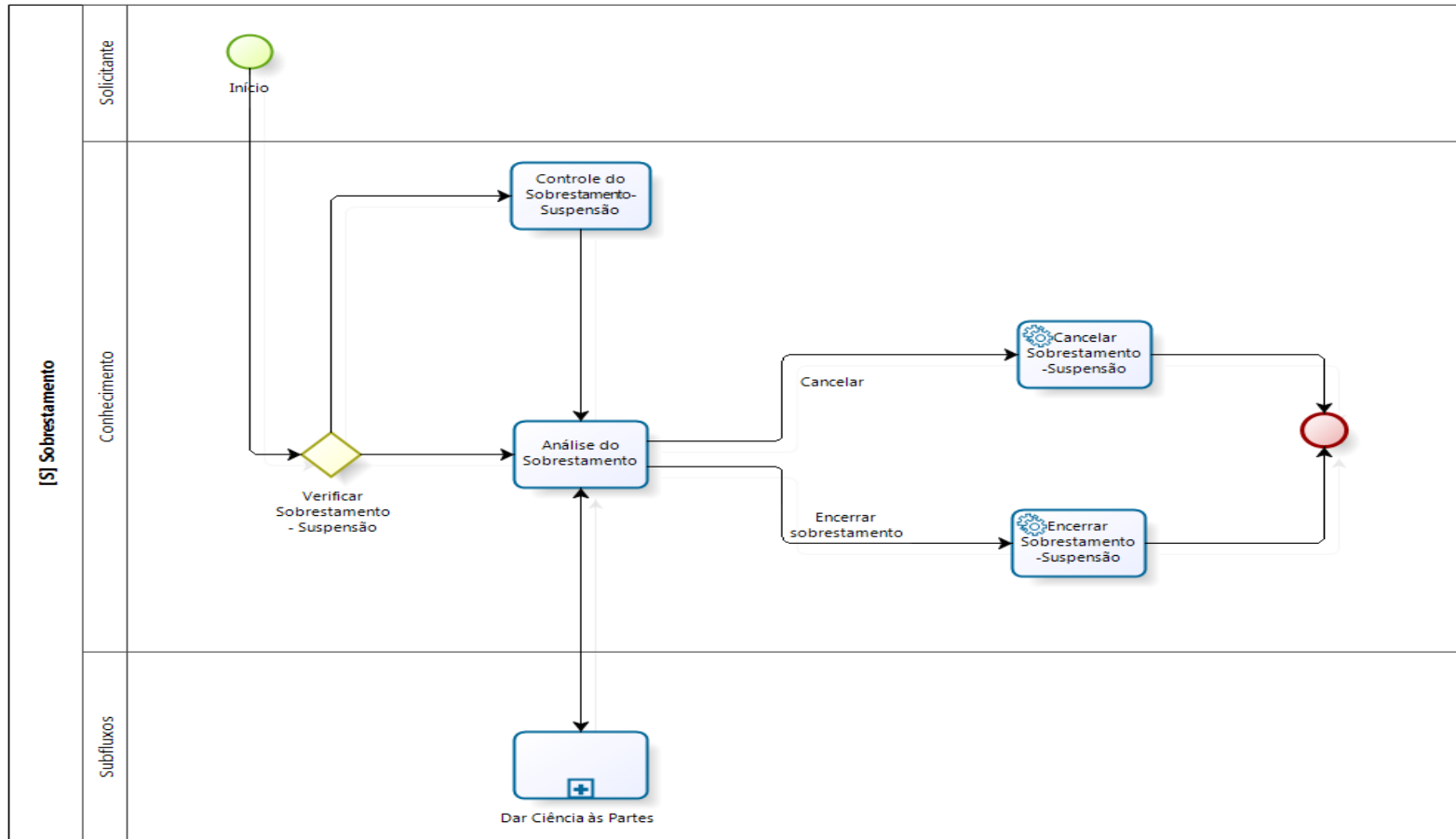

13 [CPRECORD] CARTA ORDEM-PRECATÓRIA

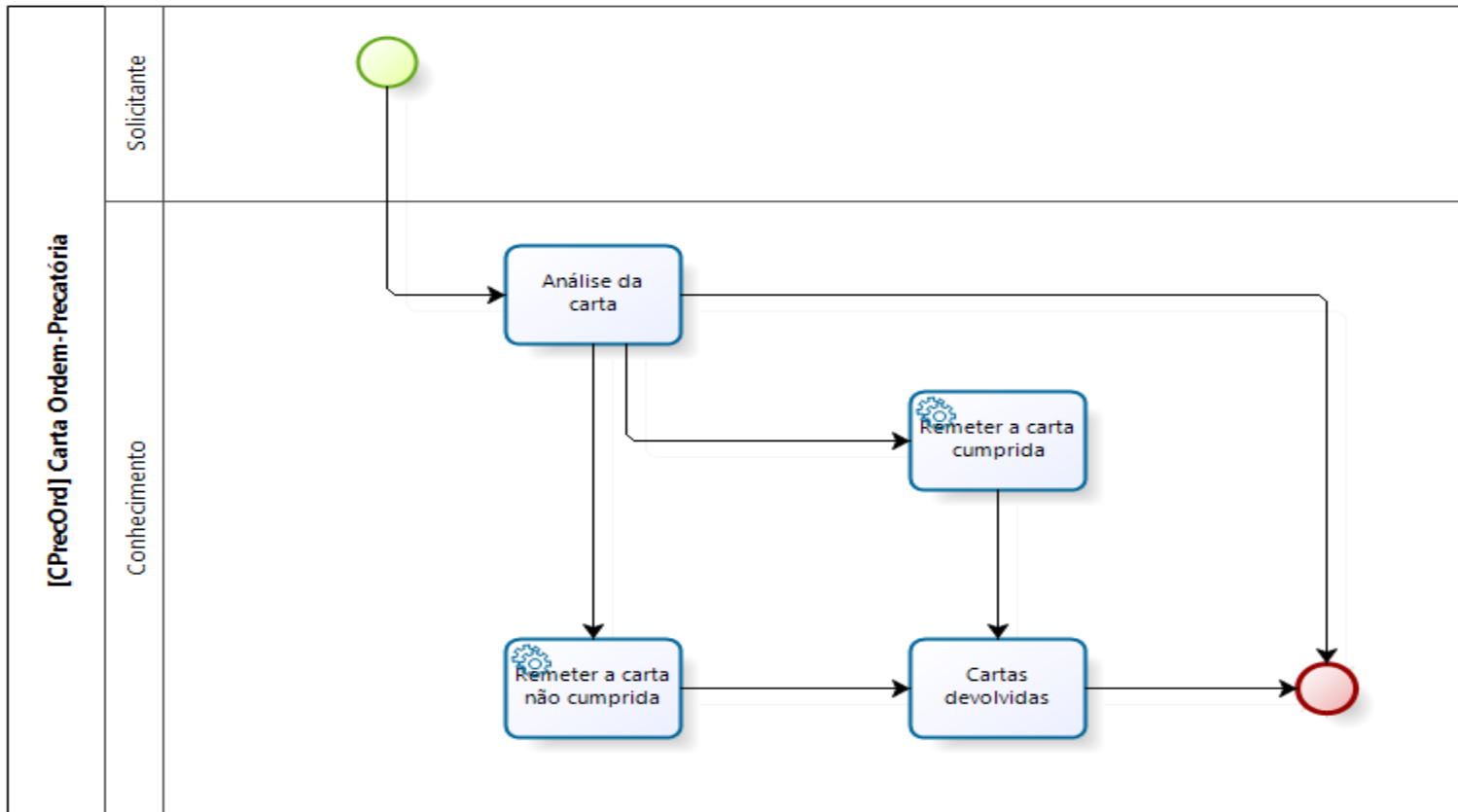

14 [ED] EMBARGOS DE DECLARACAO

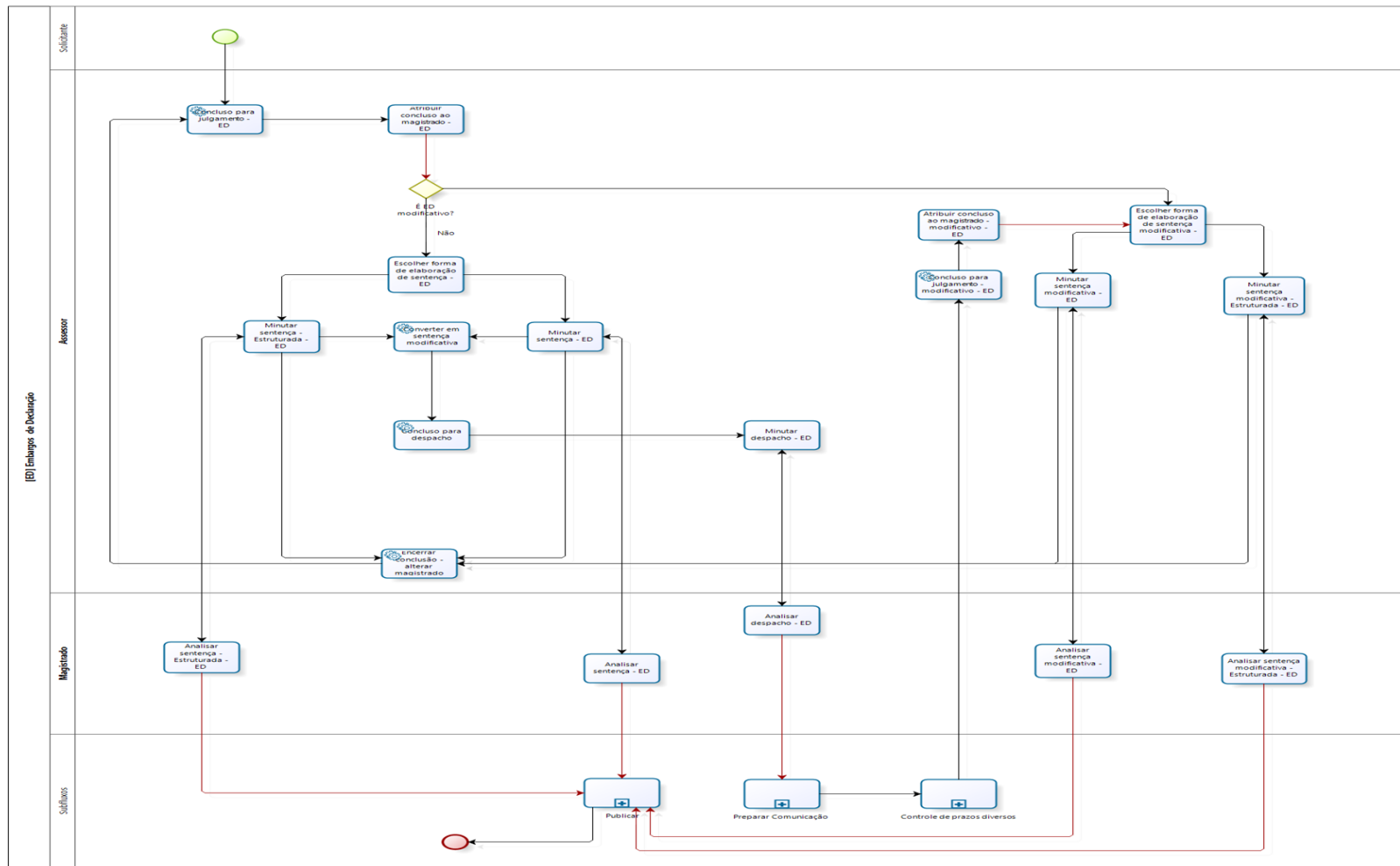

15 [REM2G] REMESSA PARA 2o GRAU

